

chiron

CNC Machining Centres

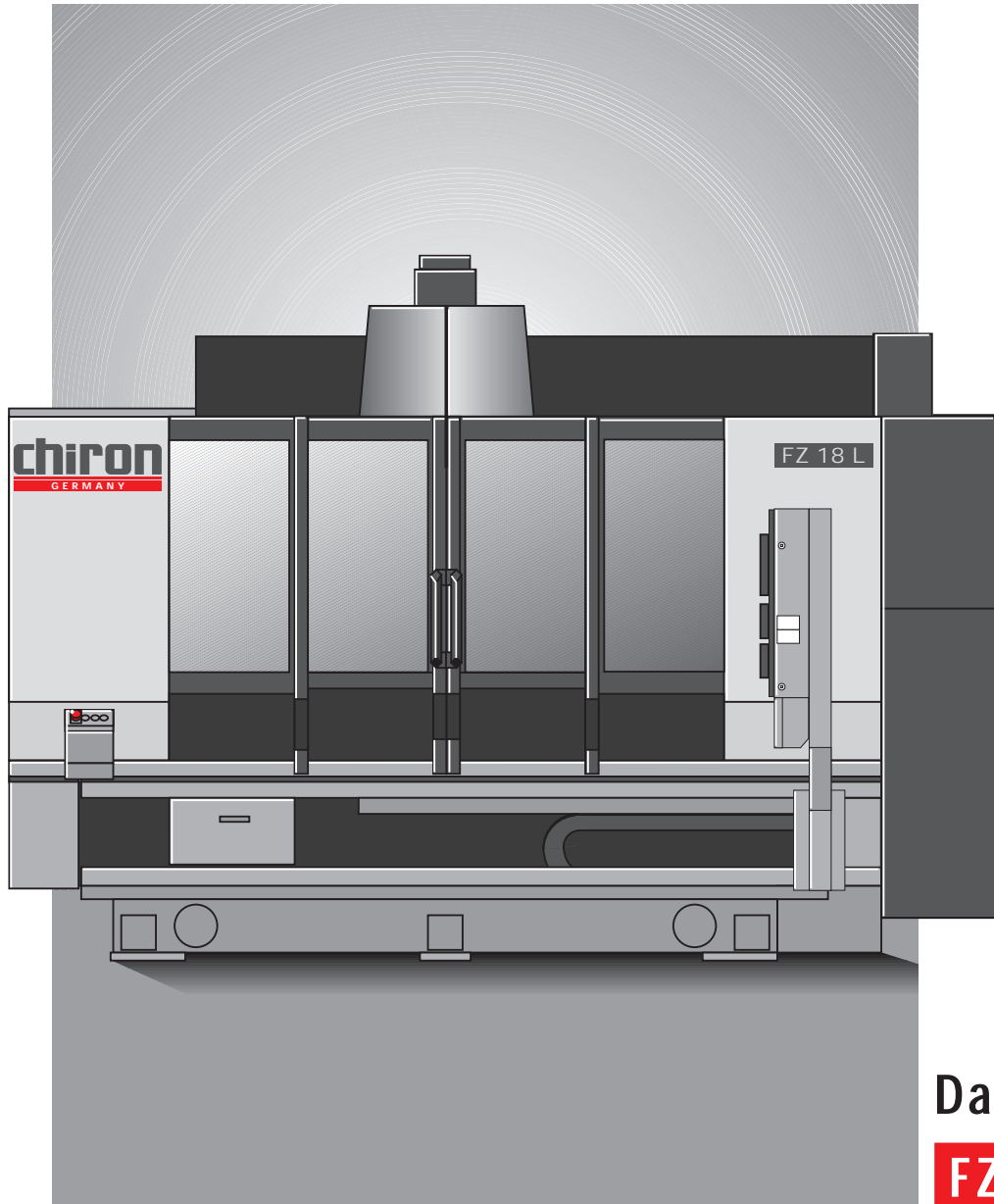

Datasheet

FZ 18 L

ISO 40

Tools 20/36

Chip-to-chip 2.4s/3.5 s

Spindle speed up to 10 500 rpm

Rapid X 40 m/min

Seconds ahead

FZ 18 L

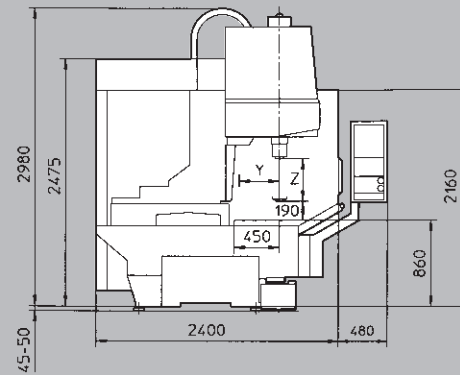
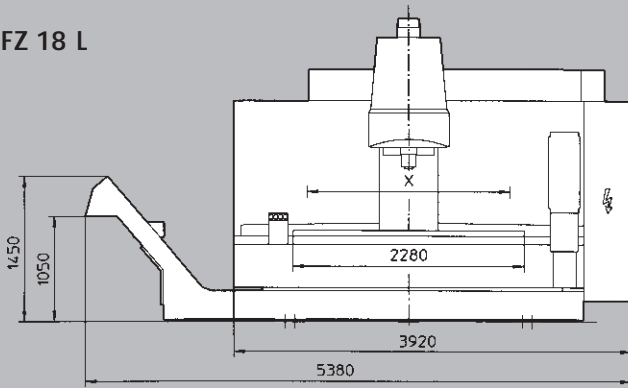

Technical data

Drilling capacity in ST 60 with carbide drill	42 mm	
Tapping	M 30	
Milling capacity in ST 60	300 cm ³ /min	360 cm ³ /min
Tool storage capacity	20	36
Tool taper ISO 7388	ISO 40	ISO 40
Max. tool diameter	65 mm	75 mm
If adjacent places are free	180 mm	105 mm
Max. tool weight	5 (8) kg	8 (12) kg
Tool change time	approx. 0.9 s	approx. 1.5 s
Chip-to-chip time	approx. 2.4 s	approx. 3.5 s
Spindle drive AC	18 kW	
Infinitely variable speed range	20 - 7 100 rpm	
Max. torque	140 Nm	
Diameter front spindle bearing	70 mm	
Tool clamping	mechanically locked	
Distance spindle to column	435 mm	415 mm
Distance spindle nose to table surface	190 - 615 mm	
Feed force X-axis, Y-axis	5 000 N	8 000 N
Feed force Z-axis	10 000 N	
Rapid feed rate X-axis	40 m/min	
Rapid feed rate Y-axis, Z-axis	30 m/min	
Fixed table ,T-slots	2 x 18 H 12	
Reference slot	18 H 8	
Chip conveyor, discharge height	1 050 mm	
Coolant device, container capacity	450 l	
Full enclosure	illuminated	
Total connected power	approx. 20 kVA	
Air connection	6 bar	

Options

■ **NC rotary table with basic fixture**

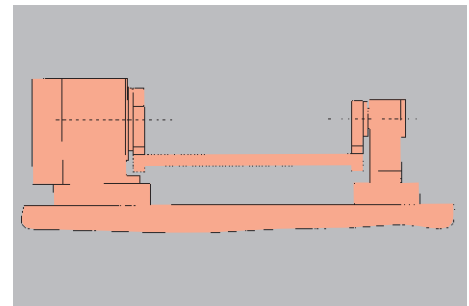

■ **Higher spindle drive with increased speed range (26 kW/300 Nm)**

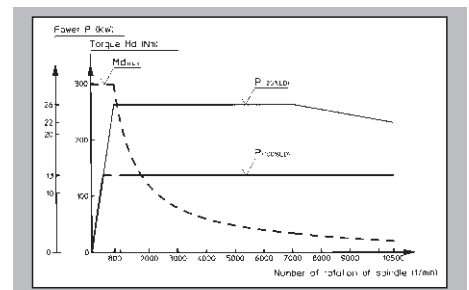

Increased speed range	20 - 10 500 rpm
Max. torque	140 Nm
Spindle drive AC	18 kW
Higher spindle drive AC	26 kW
Speed range	20 - 7 100 rpm/alt. 10 500 rpm
Max. torque	300 Nm
Travel z-axis	630 mm

- Full enclosure with extraction
- Automatic doors
- Chiron-laser-control
- Through the spindle coolant up to 70 bar
- NC rotary table
- Workpiece transport and hopper equipment
- Probe, tool measurement and management
- Drill fracture control and tool life management
- Direct path measuring system
- Tool taper HSK-A 63
- Multi-spindle head adaptor
- Thermocontrol

Travel X-axis mm	2000	2600	3200	4 500	6 300	8 000
Travel Y-axis mm	400	400	400	400	400	400
Travel Z-axis mm	425	425	425	425	425	425
Fixed table length mm	2280	2910	3540	4900	7200	9200
Fixed table width mm	450	450	450	450	450	450
Shuttle operation max. mm	2 x 750	2 x 1 050	2 x 1 350	2 x 2 000	2 x 2 900	2 x 3 750
Machine weight t	6	6.5	7	8.5	12	16
Floor space m ²	9.5	11.6	13.8	16.6	26	35