

chiron

CNC Machining Centres

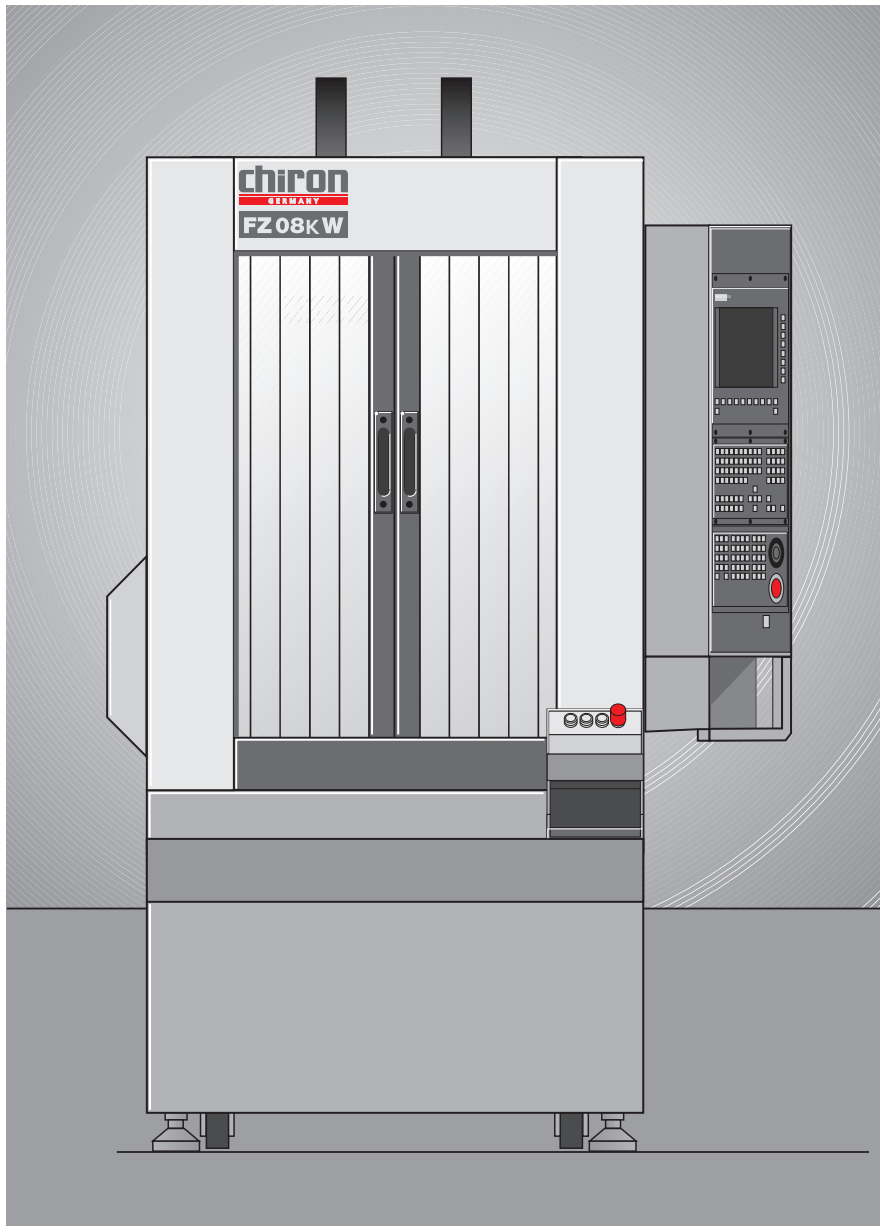

Datasheet

FZ 08K W

HSK-A 32

Tools 24

Tool change 0.8 s

Chip-to-chip 2.2 s

Spindle speed up to 27000 rpm

Workpiece change in 2,0 s

Seconds ahead

FZ 08 K W

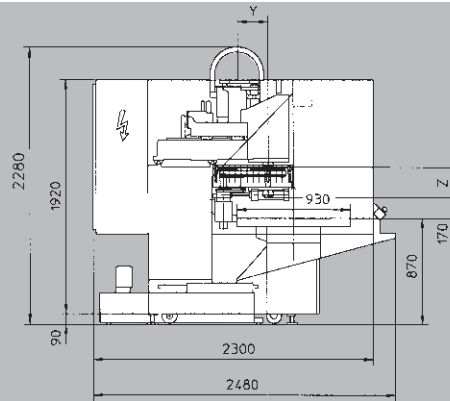
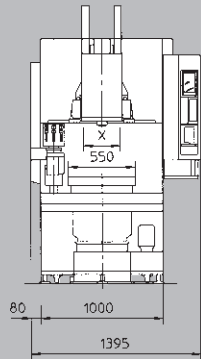

Technical data

Drilling capacity in ST 60 with carbide drill	16 mm
Tapping	M 12
Milling capacity in ST 60	20 cm ³ /min
Tool storage capacity	24
Tool taper DIN 69893	HSK-A 32
Max. tool diameter	40 mm
If adjacent places are free	50 mm
Max. tool weight	0.7 kg
Max. tool length	160 mm
Tool change time	approx. 0.8 s
Chip-to-chip time	approx. 2.2 s
Spindle drive	3.7 kW
Infinitely variable speed range	20 - 8500 rpm
Max. torque	23 Nm
Max. speed 8500 rpm	in 0.4 s
Max. tapping	up to 6000 rpm
Diameter front spindle bearing	40 mm
Tool clamping	2500 N
Distance spindle to column	200 - 450 mm
Distance spindle nose to table surface	170 - 420 mm
Travel X-axis	300 mm
Travel Y-axis	250 mm
Feed force X-axis, Y-axis	2000 N
Travel Z-axis	250 mm
Feed force Z-axis	3000 N
Rapid feed rate X-axis/Y-axis	40 m/min
Rapid feed rate Z-axis	60 m/min
Workpiece change setup	0°/180°
Mounting surface	2 x 550 x 300 mm ²
Dowel and bolt hole pattern	M 16 x Ø 15 ^{H7} x 50 mm
Workpiece change time	approx. 2,0 s
Max. transport load per side	100 kg
Coolant device, container capacity	100 l
Full enclosure	illuminated
Total connected power	approx. 10 kVA
Machine weight	1.8 t
Floor space	2.3 m ²
Air connection	6 bar

Options

■ Chip conveyor with high pressure coolant up to 150 bar

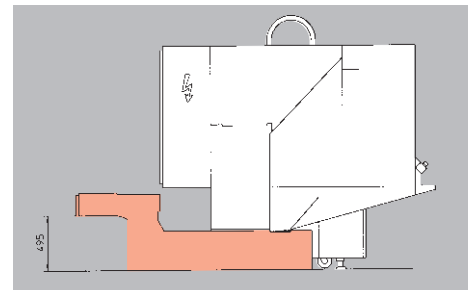

■ NC rotary table with basic fixture

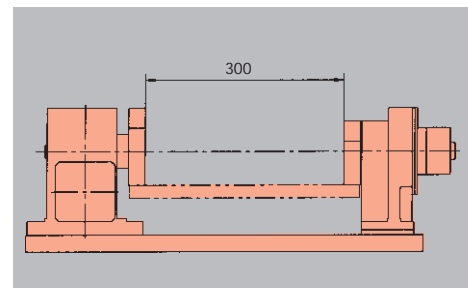

Increased speed range	20 - 15 000 rpm	20 - 27 000 rpm
Max. torque	23 Nm	8 Nm
Spindle drive	7.4 kW	3.7 kW
Max. speed	in 0.6 s	in 1.9 s

■ Tool changeable speeder head 90 000 rpm ■ Through the spindle coolant at least 15000 rpm, 70 to 150 bar ■ Electrical interface for robot ■ Automatic doors ■ Chiron-laser-control ■ Thermocontrol ■ Tool life mangement ■ Probe ■ Extraction